



# Cimatrice mobile doppia



•Double mobile pruner

- Sistema barre in autolivello che mantiene la posizione assegnata durante le regolazioni di brandeggio
  - Aggancio al trattore mediante piastra rapida;
  - Nessun deposito di tralci sulla macchina;
  - Lame senza necessità di registrazione;
  - Barra orizzontale posizionabile a qualsiasi altezza;
  - Innesti rapidi per veloce configurazione;
  - Nuovo biellismo a ridottissimo ingombro.
- Self-levelling boom system that maintains the assigned position during radial traversing
  - Mounted on tractor using a quick-fit mounting plate;
  - No vine shoot deposits on the machine;
  - Adjustment-free blades;
  - Horizontal boom can be positioned at any height;
  - Quick-fit couplings for rapid configuration;
  - New extremely compact linkage system.

sistema brevettato /patented system  
(n.002759829-0001)



## ALLESTIMENTO STANDARD

- Distributore elettroidraulico con joystick
- 2 Barre bilama su premilama integrale lubrificato in polizene, ammortizzatore a molla con pressione regolabile (sistema brevettato), bielle in scatola di protezione, misura: 170-180, 200 cm;
- Cavalletto per messa a riposo;
- Piastra aggancio rapido brevetto Lotti;
- Movimenti: brandeggio, alzata, rotazione testa, tutti indipendenti per i due lati.

## STANDARD EQUIPMENT

- Electrohydraulic distributor with joystick
- 2 x Twin blade cutter booms with integral polyzene lubricated blade guide plate, spring damper with adjustable pressure (patented system), connecting rods housed in protective casing, size: 170-180, 200 cm;
- Support stand;
- Quick-fit mounting plate, Lotti patented;
- Movements: independent head radial traversing, raising and rotation on both sides.

## DATI TECNICI / TECHNICAL DATA

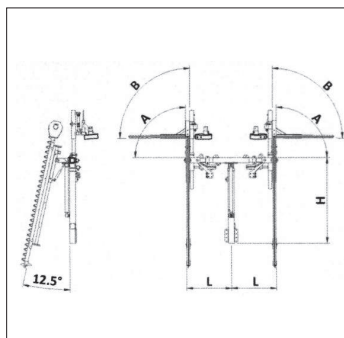

|            |         |         |  |
|------------|---------|---------|--|
| <b>H</b>   |         |         |  |
| min/max cm | 130     | 190     |  |
| <b>L</b>   |         |         |  |
| min/max cm | 25      | 100     |  |
| <b>A</b>   |         |         |  |
| min/max    | -15°    | +90°    |  |
| <b>B</b>   |         |         |  |
| min/max    | 0°      | 90°     |  |
| <b>kg</b>  |         |         |  |
|            | 350 ca. | 410 ca. |  |

**ACCESSORI A RICHIESTA**

- 05\_Barra bilama cm 100 con rotazione regolabile mediante martinetto idraulico e scansapiante a pressione regolabile;
- 08\_Kit stralciatore "brevetto Lotti" a spirale motorizzato con scansa piante a pressione regolabile;
- 09\_kit alza tralci;
- 10\_Spollonatore;
- 11\_Defogliatore;
- 12\_Attacco a tre punti per sollevamento anteriore o trattore reversibile;
- 14\_kit barra da secco con scansa piante a pressione regolabile;
- 30\_Barre potatrici per frutteto;
- 47\_Impianto idraulico indipendente con scambiatore di calore;
- 48\_Spollonatore verticale;
- 52\_Barra bilama inferiore da cm 100 con martinetto idraulico e scansa piante a pressione regolabile;
- 53\_Testata prepotatrice a dischi piccoli con movimenti idraulici;
- 54\_Testata prepotatrice per kiwi con movimenti idraulici.



14\_



09\_



05\_

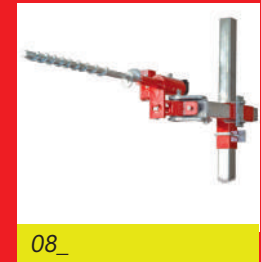

08\_



48\_



10\_



11\_

**OPTIONAL ACCESSORIES**

- 05\_Twin blade cutter boom length 100 cm with adjustable rotation movement using hydraulic jack and adjustable pressure plant buffer;
- 08\_Lotti patented motorised spiral pruner kit with adjustable pressure plant buffer;
- 09\_Shoot pick-up kit;
- 10\_Sucker remover;
- 11\_Defoliator;
- 12\_Reversible three-point hitch for front lifting or tractor;
- 14\_Dry boom kit with adjustable pressure plant buffer;
- 30\_Pruner booms for orchards;
- 47\_Independent hydraulic system with heat exchanger;
- 48\_Vertical sucker remover;
- 52\_Lower twin blade cutter boom length 100 cm with hydraulic jack and adjustable pressure plant buffer;
- 53\_Small disc prepruning head with hydraulic movement;
- 54\_Prepruning head with hydraulic movement for kiwis.



12\_



47\_



30\_



52\_



53\_



54\_

